

5-1 Threading Wire



WARNING

- Be sure to turn power off whenever setting stitcher heads.

1. Draw wire from the bottom of coil, and thread wire through slot at the end of wire guide, through wire guides and through upper wire straightener.

NOTE

- Make sure that wire is loaded on coil holder stud so that wire is fed counterclockwise from the bottom of coil.

2. Adjust wire brake pressure.

- When coil has much wire to stitch, release wire brake pressure.
- When coil has less wire to stitch, apply wire brake pressure.

NOTE

- If wire brake pressure is too loose, coil will continue to rotate after stitcher head stops. This cause wire to tangle.

- If wire brake pressure is too tight, full length of wire will not be fed for each stitch. This causes different length of stitch.

3. Thread wire through upper wire straightener and between tension pawl and tension roll.

4. Adjust upper wire straightener so that wire is bent a little as shown in the figure below.

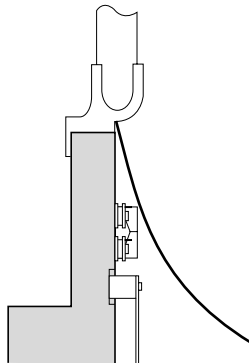

Face Plate

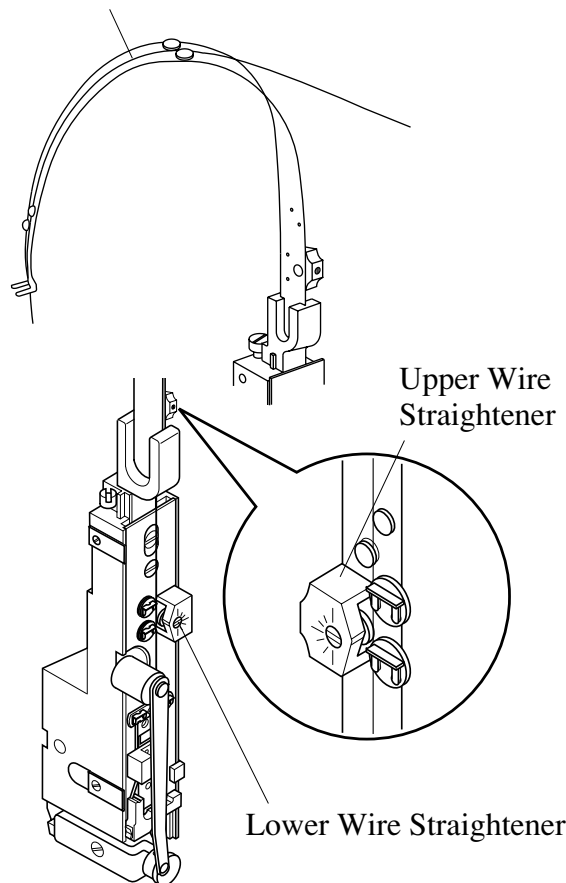
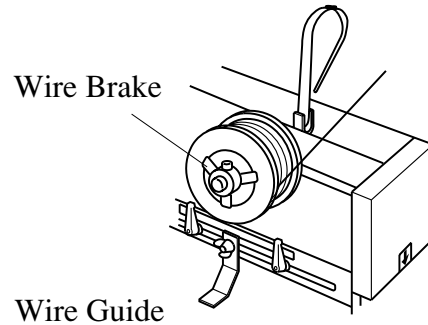

Turn clockwise to weaken the tension.
Turn counterclockwise to strengthen the tension.
(Standard Position: horizontal or a little downward)

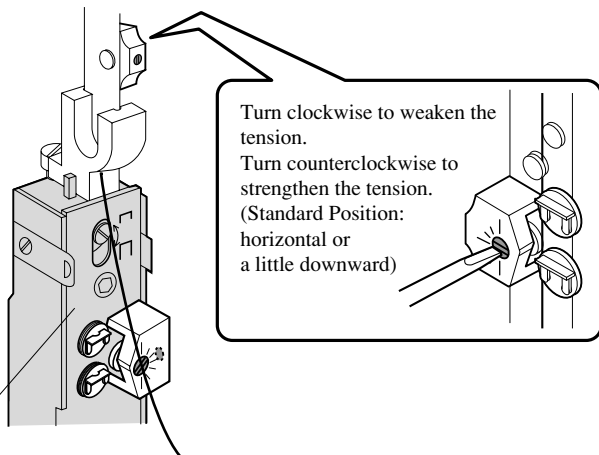

5-1 Threading Wire

5. Adjust lower wire straightener so that the wire curves slightly to the right.

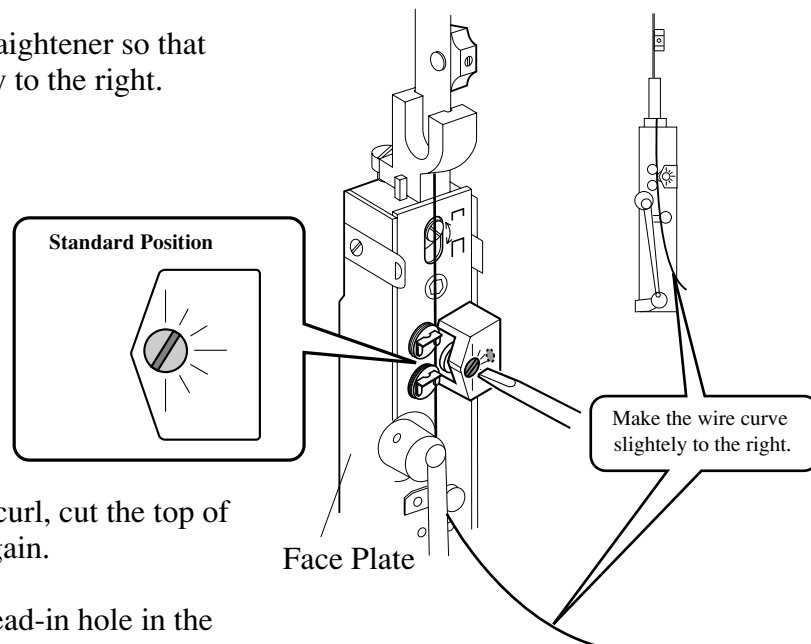

6. If the wire still has a curl, cut the top of the wire and thread it again.

7. Feed wire into wire lead-in hole in the bottom of face plate.

8. Open the gripper and catch the wire with the gripper.

How to open the gripper:

- Press the stitcher inching button and stop the stitcher head at the position where it raises a little from the bottom.

At this position, the gripper is opening.

9. Place some sheets under stitcher heads and press stitcher inching button to check if wire is correctly threaded.

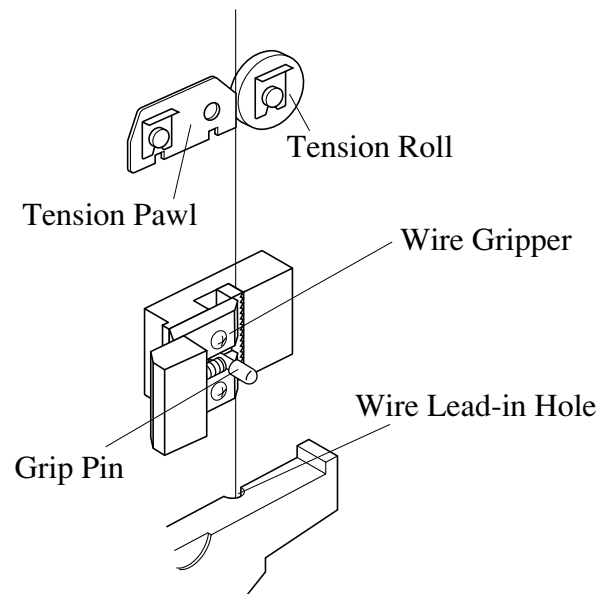

CAUTION

- Do not operate stitcher heads with no sheets placed under stitcher heads.
- Avoid driving a stitch on top of another stitch. This may cause stitcher heads to be damaged.

NOTE

- Stitcher inching button must be pressed until stitcher heads stitch sheets with wire.

10. When stitcher heads do not work correctly, check that clincher and wire straightener are set up properly, and wire is threaded properly, and also examine if wire does not buckle or crack.

5-2 Adjusting Stitch Length

Follow the following procedure to equalize both legs of stitch.

1. Loosen fix screw.
2. Turn stitch length adjust screw clockwise to shorten left leg of stitch ; counterclockwise to lengthen left leg.
3. Tap bracket down before fastening fix screw.

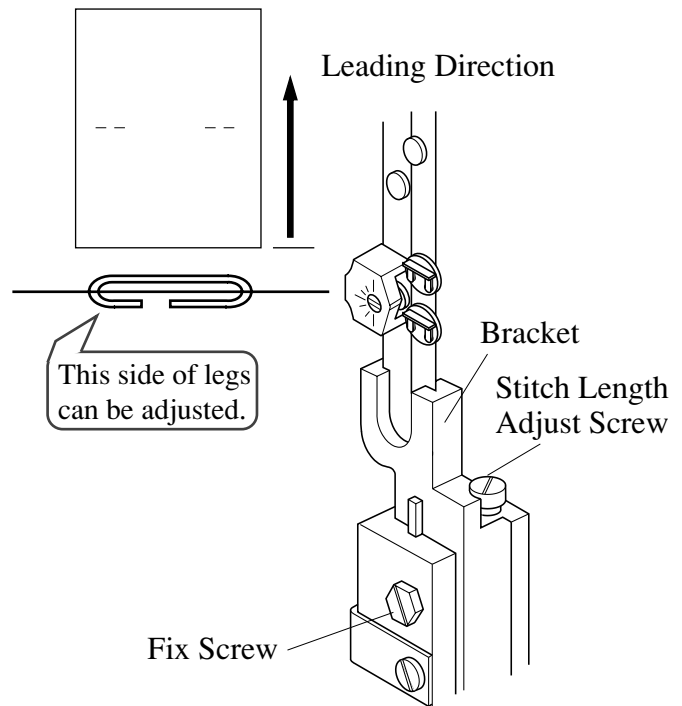

5-3 Changing for Work Thickness

The movement of face plate regulates the length of stitch legs and the amount of work compression.

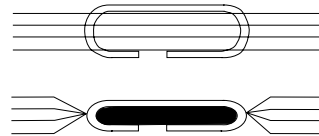

1. Loosen face plate fix screw.
2. To move the face plate up or down, turn the face plate up/down adjust screw.

Thick : Turn the screw clockwise to raise the face plate.

Thin : Turn the screw counterclockwise to lower the face plate.

ATTENTION

- Do not raise the face plate over 5.0 mm (0.20"). Otherwise, the stitch operation cannot be performed.

3. Tighten face place fix screw securely.

NOTE

- If face plate is lowered too much when thin or light sheets are handled, driver end may cut into sheets. Raise face plate slightly.

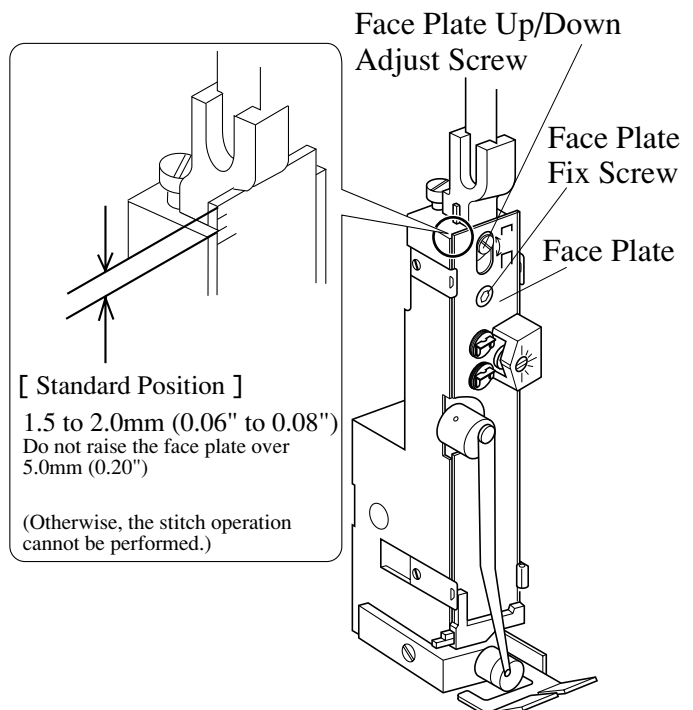

5-4 Adjusting Stitcher Head and Clincher Position

When the position of the stitcher head is changed, change the position of the clincher also.

